

Without wishing to lay too much stress upon this conclusion, the writers would point out that such a "hydroxyl" scheme is at least as probable a mechanism of hydrocarbon oxidation as a peroxide scheme, especially when it is considered that hydrocarbons generally do not react appreciably with oxygen until they reach temperatures at which dissociation begins to occur.

One of the authors (R. S.) wishes to express his indebtedness to the Commonwealth Fund for a Fellowship which enabled him to take part in the research.

### Summary

1. Gaseous methyl iodide decomposes extremely slowly when illuminated with ultraviolet light, and exhibits a Budde effect similar to that obtained with chlorine.

2. The photo-oxidation of gaseous methyl iodide has been shown to be essentially an oxidation of free methyl groups.

3. Iodine, paraformaldehyde, methylal and water are practically the sole products of reaction.

4. The kinetics of the process have been investigated and found to agree with the theoretically derived mechanism.

PRINCETON, NEW JERSEY

[CONTRIBUTION FROM THE DEPARTMENT OF CHEMISTRY OF WASHINGTON SQUARE  
COLLEGE, NEW YORK UNIVERSITY]

## THE OXIDATION OF IODIDE ION BY PERSULFATE ION. IV. KINETICS OF THE REACTION IN HIGHLY DILUTE AQUEOUS SOLUTION

BY CECIL V. KING AND MORRIS B. JACOBS

RECEIVED FEBRUARY 3, 1931

PUBLISHED MAY 6, 1931

### Introduction

A combination of Brönsted's equation for the velocity of a bimolecular ionic reaction and the Debye-Hückel limiting expression for the activity coefficient of an ion (in water at 25°) leads to the expression

$$\log k = \log k_0 + z_A z_B \sqrt{\mu} \quad (1)$$

where  $k$  is the velocity constant observed and  $k_0$  that at zero ionic strength. Introduction of the Debye-Hückel expression necessitates velocity measurements at very low salt concentrations to test this expression; previously only three ionic reactions have been measured at concentrations below  $\sqrt{\mu} = 0.14$  and two others below  $\sqrt{\mu} = 0.25$ . An excellent summary of this work has been given by Livingston<sup>1</sup> and we have reproduced his plot of  $(\log k - \log k_0)$  against  $\sqrt{\mu}$  for the various reactions, including for comparison (in black circles, Fig. 1) some of our measurements on the persulfate-iodide reaction.

<sup>1</sup> Livingston, *J. Chem. Ed.*, 7, 2887 (1930).

This reaction has been the subject of several previous investigations at higher ionic strengths than reported here. Price<sup>2</sup> found the reaction to be kinetically bimolecular, and noted the positive salt effect. He also observed the disturbing influence of the iodine formed in the course of the reaction on the velocity, a factor which has been clarified in this Laboratory (papers I and II of this series) and elsewhere.<sup>3</sup> Brönsted used the earlier measurements in verifying his theory of primary salt effect.<sup>4</sup>

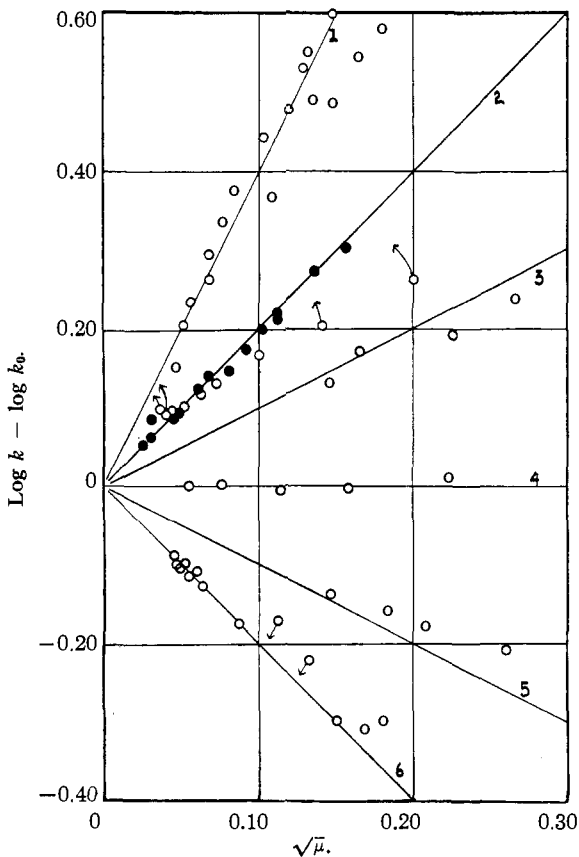

Fig. 1.—The effect of ionic strength on the velocity of ionic reactions.

### The Experimental Method

The reaction has been followed in the past by titrating the iodine produced with standard thiosulfate. Such titrations become difficult in the

<sup>2</sup> Price, *Z. physik. Chem.*, 27, 474 (1898).

<sup>3</sup> Jette and King, *THIS JOURNAL*, 51, 1034, 1048 (1929); Oostveen, *Rec. trav. chim.*, 48, 697 (1929).

<sup>4</sup> Brönsted, *Z. physik. Chem.*, 102, 169 (1922).

dilute solutions we wished to use, although the similar titration of thiosulfate with standard iodine has been carried out successfully in equally dilute solutions.<sup>5</sup> However, in addition to this difficulty we wished to avoid also the complicating factor of tri-iodide formation mentioned above, and therefore resorted to a scheme similar to that used in studying the Landolt reaction ( $\text{HIO}_3 + \text{H}_2\text{SO}_3 \longrightarrow$ ). To the solution of potassium persulfate and potassium iodide was added a small amount of sodium thiosulfate, which by its very rapid reaction with the iodine as it was liberated, kept the solution clear until it was all used up. The time of first appearance of iodine was determined with the aid of a balanced photo-cell circuit and sensitive galvanometer, with a long absorption cell; for accuracy the amount of thiosulfate was adjusted so that the iodine never appeared in less than approximately ten minutes. From this time and the known concentrations the velocity constant was calculated.

The velocity of other reactions has been measured in a similar manner, without using a photo-cell method and at much higher concentrations. The Landolt reaction has been mentioned above. Abel measured the velocity of the potassium iodide-hydrogen peroxide reaction by adding thiosulfate (which also reacts with the hydrogen peroxide, at a known, slow rate).<sup>6</sup> Abel and Fürth studied the oxidation of iodide by periodate by using arsenite to react with the liberated iodine and so prevent its appearance.<sup>7</sup>

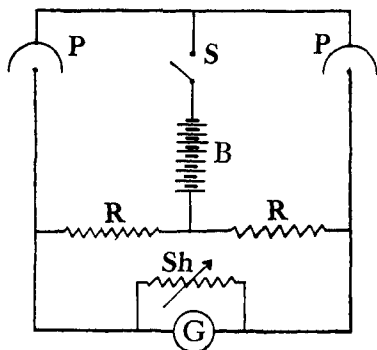

Fig. 2.—The photo-cell circuit: P, P, General Electric PJ14 photo-cells; S, switch; B, 90-volt battery; R, R, 100-000-ohm resistances; G, Leeds and Northrup wall galvanometer, resistance 1090 ohms, sensitivity 1133 meg-ohms, period 13.1 seconds; Sh, shunt box.

Thiosulfate is oxidized very slowly by persulfate,<sup>8</sup> especially in dilute solutions of persulfate and at low ionic strength, so that this factor was negligible except when the persulfate concentration was much higher than the iodide concentration, as will be noted later.

The photo-cell circuit used is shown diagrammatically in Fig. 2. Vacuum type cells were used, since the circuit was too unstable with gas-filled cells. The source of light was a 400-watt projection bulb operated on 110 volts d. c. The lamp was inclosed in a metal housing, cooled by a small fan. Two beams of light were first passed through glass filters—a combina-

<sup>5</sup> La Mer, *THIS JOURNAL*, **51**, 3341 (1929).

<sup>6</sup> Abel, *Z. Elektrochem.*, **14**, 598 (1908).

<sup>7</sup> Abel and Fürth, *Z. physik. Chem.*, **107**, 313 (1923).

<sup>8</sup> King and Steinbach, *THIS JOURNAL*, **52**, 4779 (1930).

tion of Corning "Didymium" and "Theater Blue"—to filter out most of the light not absorbed by iodine solutions. The light then passed, on one side through the reaction cell—a  $5 \times 20$  cm. glass tube with plane glass ends and side tube for filling—thermostated at  $25 \pm 0.02^\circ$ , and on the other side through a similar cell containing distilled water. The beams then passed through iris diaphragms to the two photo-cells. Sufficient light was obtained without the use of a lens system.

This balanced circuit automatically compensates for most of the fluctuations in the source of light, in battery voltage, etc. Since it is difficult to find two photo-cells with exactly similar characteristics, two 100,000 ohm resistances exactly alike, etc., this compensation is not perfect. Sometimes the galvanometer reading was quite constant over a long period of

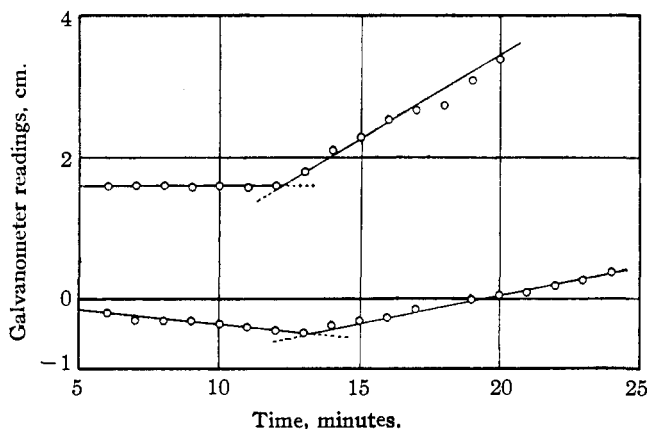

Fig. 3.—The method of obtaining the time of appearance of iodine.

time; sometimes there were small variations or a slow drift. To fix the time of appearance of iodine more exactly, galvanometer readings were plotted against time and by extrapolating as shown in Fig. 3, the time was determined to  $\pm 0.1$  minute in most cases.

The galvanometer shunt was used only while balancing the circuit and not when measurements were being made. It was found that the appearance of  $3 \times 10^{-7}$  moles per liter of iodine gave a galvanometer deflection of approximately 2 cm. The absorption of light increases somewhat more than linearly with the concentration of iodine, but the iodine appears more slowly as the time progresses, hence the approximate linearity of the curves in Fig. 3 over the first few minutes of iodine liberation.

This method gave a much more sensitive test for iodine than the visual test with starch. The latter is, according to Kolthoff,<sup>9</sup> sensitive to about

<sup>9</sup> Kolthoff, "Volumetric Analysis," John Wiley and Sons, Inc., New York, 1929, Vol. II, p. 350.

$1 \times 10^{-5}$  mole of iodine per liter (if  $4 \times 10^{-5} M I^-$  is present). This may under certain conditions be increased to  $5 \times 10^{-6}$  mole of iodine per liter.

Partington<sup>10</sup> states that one part per million of iodine (approximately  $2.5 \times 10^{-5}$  mole per liter) can be detected with starch. He also states that basic lanthanum and praseodymium acetates can be used to detect traces of iodine. Experiments in this Laboratory showed the first of these to be slightly more sensitive than starch. However, the photo-cell method was far better for our purpose.

### Materials and Method

All the water used was redistilled from dilute alkaline permanganate and condensed in a block tin condenser. All salts were recrystallized at least twice from this water. Especial pains were taken to free the potassium iodide from traces of iodine since this would react immediately with some of the thiosulfate added. Measurements made with different lots of several of the salts agreed well. Measurements at the highest ionic strengths used checked previous measurements within 2%. King and Steinbach<sup>8</sup> found the velocity of this reaction to be some 25% less in the presence of 0.02 *M* thiosulfate than in the presence of 0.02 *M* potassium sulfate. However, in the presence of  $10^{-7} - 10^{-5} M$  thiosulfate, as used in this investigation, the agreement with previous measurements indicates that the reaction is perfectly normal.

Standard solutions of all the salts except the thiosulfate were made by weighing the salt and dissolving in the required volume of water. Sodium thiosulfate was standardized by titrating the iodine liberated from potassium iodide by a known amount of persulfate.<sup>11</sup> Aliquot parts of the standard solution were diluted to the required concentrations.

All solutions were brought to 25° before mixing, the time of mixing noted, and galvanometer readings started as soon as the absorption cell was filled and in the bath.

The velocity constants were calculated from the differential equation

$$-\frac{dC_{S_2O_8^{2-}}}{dt} = kC_{S_2O_8^{2-}}C_{I^-}$$

The interval from the time of mixing until the first appearance of iodine was used as *dt*,  $-dC_{S_2O_8^{2-}}$  was calculated from the known concentration of thiosulfate, and  $C_{S_2O_8^{2-}}$ ,  $C_{I^-}$  were the initial concentrations. Since the concentration of thiosulfate was seldom more than 2% of that of the persulfate or iodide, this procedure gives sufficiently accurate values of *k*.

### Experimental

In the first series of experiments the potassium persulfate concentration

<sup>10</sup> Partington, "Textbook of Inorganic Chemistry," The Macmillan Co., New York, 1929, p. 407.

<sup>11</sup> Paper III of this series, THIS JOURNAL, 52, 608 (1930).

was varied from 0.000125 to 0.0048 *M*, and the potassium iodide from one to three times the persulfate concentration. The values of  $\sqrt{\mu}$  and  $\log k$  are given in Table I; to save space, the concentrations are omitted. In

TABLE I

THE EFFECT OF THE TOTAL IONIC STRENGTH ON THE VELOCITY OF THE PERSULFATE-  
IODIDE ION REACTION AT 25°

$C_{K_2S_2O_8}$  0.000125 to 0.0048 *M*;  $C_{KI}$  one to three times  $C_{K_2S_2O_8}$ ;  $C_{Na_2S_2O_3}$   $7 \times 10^{-7}$  to  $3 \times 10^{-4}$  *M*

$\sqrt{\mu}$	Log <i>k</i>	$\sqrt{\mu}$	Log <i>k</i>	$\sqrt{\mu}$	Log <i>k</i>
0.0250	̄.978	0.0571	̄.1049	0.0841	̄.1068
.0308	0.987	.0571	0.053	.1002	0.100
.0308	̄.1013	.0592	.045	.1272	.100
.0308	0.009	.0592	.057	.1426	.121
.0354	.009	.0592	.061	.1426	.111
.0354	.021	.0654	.065	.1429	.114
.0354	.021	.0654	.072	.1490	.121
.0419	.017	.0654	.057	.1500	.124
.0419	.033	.0709	.090	.1574	.114
.0419	.037	.0709	.086	.1574	.111
.0500	.037	.0808	.072	.1574	.117
.0500	.045	.0808	.079	.1590	.124
.0571	.072	.0840	.068		

Fig. 4,  $\log k$  is plotted against  $\sqrt{\mu}$ . The straight line is drawn with the slope +2 in such a way that it best fits the points at the lowest values of

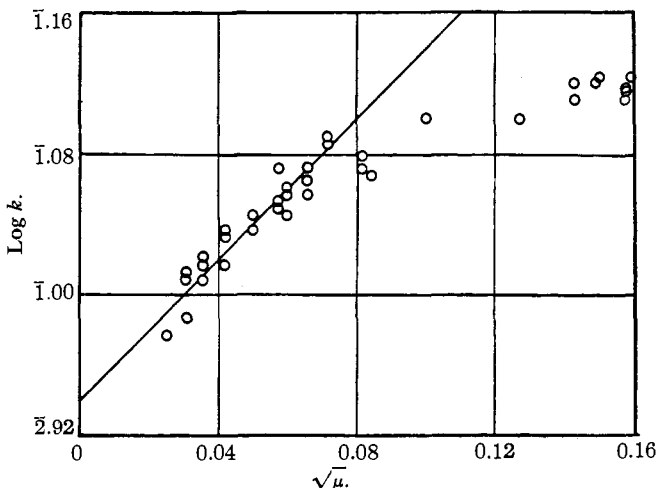

Fig. 4.—Experiments with persulfate and iodide in approximately equivalent concentrations.

$\sqrt{\mu}$ ; it is evident that the experimental values agree with the theoretical up to  $\sqrt{\mu} = 0.06$ , but that above this value there is an increasing negative

deviation. Since the best straight line extrapolates to  $\log k_0 = \bar{2}.94$  or  $-1.06$ , Equation 6 becomes

$$\log k = -1.06 + 2\sqrt{\mu}$$

The figure  $-1.06$  is not, however, the value we shall accept as best for  $\log k_0$  (see discussion at end of paper).

Since we should expect to find a reaction in solutions containing only univalent ions to follow the theoretical expressions to much higher ionic strengths than if bivalent ions are present, it appears that the above method of using mixtures containing uni- and bivalent ions is a poor choice. It would be preferable to keep the concentration of persulfate as low as possible and increase the iodide concentration, or keep both low and add an inert salt to raise the ionic strength. This was accordingly done in the succeeding experiments.

In the second series the potassium persulfate concentration was kept at  $0.00015 M$  and the potassium iodide concentration at  $0.0005 M$  (except for the four lowest points), while potassium chloride was added to raise the ionic strength. In a parallel series the persulfate concentration was kept at the same value while increasing concentrations of iodide were used to raise the ionic strength. The results are given in Tables II and III and plotted

TABLES II AND III

THE EFFECT OF UNI-UNIVALENT SALTS ON THE VELOCITY					
0.00015 M $K_2S_2O_8$ , 0.0005 M KI, $1.7 \times 10^{-7}$ to $4 \times 10^{-7}$ M $Na_2S_2O_3$			0.00015 M $K_2S_2O_8$ , $6 \times 10^{-7}$ to $2 \times 10^{-6}$ M $Na_2S_2O_3$		
$C_{KCl}$	$\sqrt{\mu}$	Log $k$	$C_{KI}$	$\sqrt{\mu}$	Log $k$
0.00015	0.0336	$\bar{1}.004$	0.0016	0.0452	$\bar{1}.013$
.0003	.0354	0.017	.0020	.0495	0.021
.0006	.0393	.000	.0032	.0604	.049
.0012	.0464	.009	.0040	.0667	.065
.0018	.0524	.017	.0060	.0803	.072
.0036	.0675	.057	.0080	.0919	.100
.0054	.0797	.083	.010	.1022	.124
.0060	.0834	.079	.012	.1116	.146
.0060	.0834	.076	.012	.1116	.140
.0072	.0903	.107	.018	.1358	.199
.0090	.0998	.111	.024	.1564	.228
.0096	.1028	.117			
.012	.1138	.140			
.012	.1138	.134			
.0144	.1239	.164			
.018	.1376	.199			
.024	.1580	.230			

in Fig. 5, the experiments with added potassium chloride as open circles, those with potassium iodide as black circles. Here the best straight line with the slope  $+2$  through the lowest points extrapolates to the value  $\log k_0 = \bar{2}.925$  or  $-1.075$ , which is only 1.6% different from the value found

before and probably within the experimental error of such velocity measurements. It will be seen that these experiments follow the theoretical slope quite well to  $\sqrt{\mu} = 0.16$ , the highest value used. The theoretical equation becomes

$$\log k = -1.075 + 2\sqrt{\mu}$$

In the fourth series an attempt was made to keep the potassium iodide concentration low ( $0.0005 M$ ) and raise the ionic strength by adding larger amounts of potassium persulfate. These results are plotted in Fig. 6 (open circles). It will be seen that the results are not in accord with the

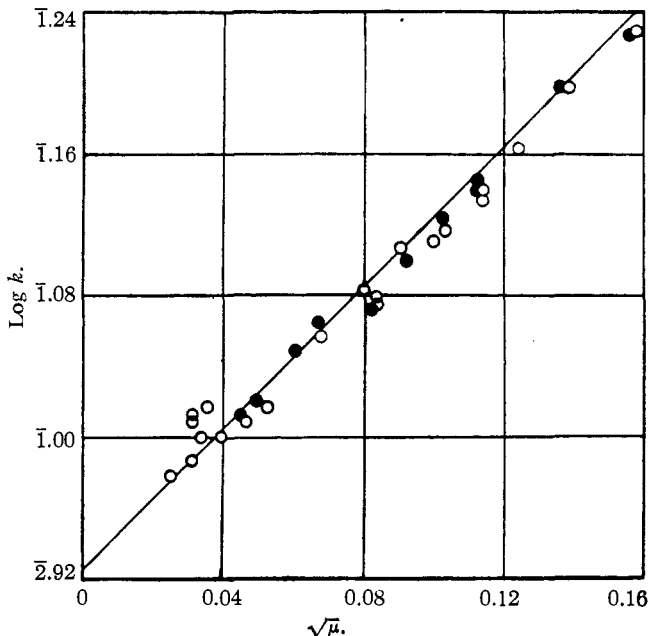

Fig. 5.—Persulfate concentration low; ionic strength raised by adding KCl (O) and KI (●).

theory in that the value of  $k$  rises far above the theoretical and at higher ionic strengths actually decreases again. The explanation lies in the fact that in most of these experiments the ratio of persulfate to thiosulfate concentrations was such that an appreciable percentage of the thiosulfate is oxidized directly instead of through the intermediate iodine. It was found before<sup>8</sup> that the rate of the persulfate-thiosulfate reaction is much more dependent on the persulfate concentration than on the thiosulfate concentration. In these experiments, with  $0.00015 M$  persulfate and  $5 \times 10^{-7} M$  thiosulfate, not over 1% of the thiosulfate is oxidized directly; while with  $0.004 M$  persulfate and  $1 \times 10^{-5} M$  thiosulfate the percentage is much larger. The iodide concentration was low; if this were raised to twice the



persulfate concentration, as in the first series, the velocity of the main reaction would be increased 10–20 times and again not over 1% of the thiosulfate would be oxidized directly.

When the persulfate concentration was increased to the highest value used, 0.012 *M*, the thiosulfate concentration had to be increased to  $4 \times 10^{-5}$  *M*, almost 10% of the iodide concentration; the velocity of the main reaction was such that the percentage of thiosulfate oxidized directly was again low; while the fact that the differential equation was used to calculate *k* introduces an error of a few per cent.

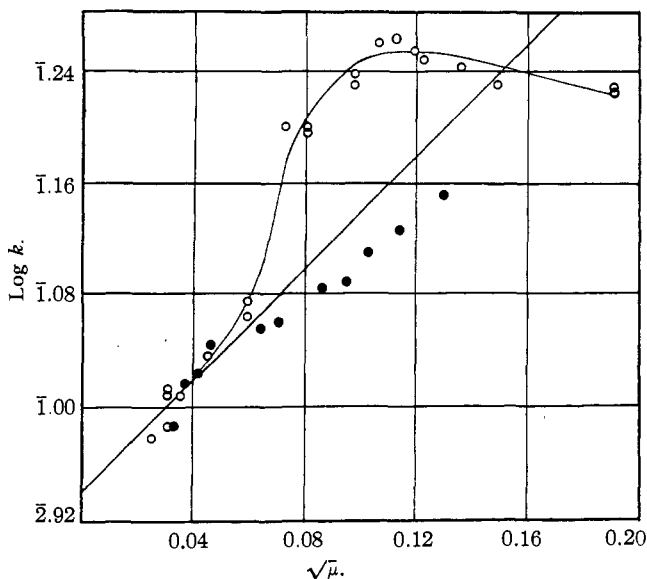

Fig. 6.—Iodide concentration low; ionic strength raised by adding  $K_2S_2O_8$  (O) and  $MgSO_4$  (●).

Calculation shows that if we assume a value of  $2.5 \times 10^{-5}$  as an average for the unimolecular constant of the persulfate–thiosulfate reaction over this range of ionic strengths, and correct the curve shown in Fig. 6 accordingly, reasonable values are obtained for the persulfate–iodide velocity. Unfortunately, no direct measurements of the persulfate–thiosulfate reaction at such low ionic strengths are available, but this value is not improbable.

To obtain better values for the effect of bivalent ions on this reaction, in the last series both the persulfate and iodide concentrations were kept low (0.00015 and 0.0005 *M*, respectively) and magnesium sulfate was used to raise the ionic strength. The results are given in Table IV and plotted in Fig. 6 (black circles). Here we see that the results are normal, the theoretical slope is followed to  $\sqrt{\mu} = 0.05$  or 0.06, and the deviations at higher ionic strengths are in the expected direction. For the two sets of experi-

TABLE IV  
THE EFFECT OF MAGNESIUM SULFATE ON THE VELOCITY

0.0015 M  $K_2S_2O_8$ , 0.005 M KI,  $2.5 \times 10^{-7}$  to  $5 \times 10^{-7}$  M  $Na_2S_2O_3$

$C_{MgSO_4}$	$\sqrt{\mu}$	Log $k$	$C_{MgSO_4}$	$\sqrt{\mu}$	Log $k$
0.00004	0.0333	$\bar{2}.987$	0.0016	0.0857	$\bar{1}.083$
.0001	.0367	$\bar{1}.017$	.0020	.0946	0.090
.0002	.0418	0.025	.0024	.1027	.111
.0003	.0464	.045	.003	.1138	.127
.0008	.0644	.057	.004	.1302	.152
.0010	.0704	.061			

ments plotted in Fig. 6, the straight line which fits best extrapolates again to  $\log k_0 = -1.06$ .

### Discussion

It seems rather surprising that when the ionic strength is made up largely of univalent ions, the best straight line should extrapolate to  $\log k_0 = -1.075$ , while with a large proportion of bivalent ions present the best straight line should extrapolate to  $\log k_0 = -1.06$ . The difference is just at the limit of experimental error, but seems too consistent to be of no significance. The explanation may lie in the inaccuracy of the Debye-Hückel equation for bivalent and trivalent ions, even in very dilute solutions. This inaccuracy was noticed by Brønsted, La Mer<sup>12</sup> and their collaborators and finally explained by Gronwall, La Mer and Sandved,<sup>13</sup> who showed that an extension of the mathematical treatment of Debye and Hückel leads to a modified equation for the activity coefficient of ions of higher valence more in accord with experiment than the limiting expression. We cannot apply the Gronwall-La Mer-Sandved extension quantitatively for lack of sufficiently accurate data, but its qualitative significance can be shown. In the region  $\sqrt{\mu} = 0.04$  to  $0.08$  (approximately) the activity coefficient of the bivalent persulfate ion ( $f_A$ ) will be somewhat smaller than  $\log^{-1}(-0.5 z_2 \sqrt{\mu})$ , and that of the iodide ion ( $f_B$ ) will be practically equal to  $\log^{-1}(-0.5 z^2 \sqrt{\mu})$ . But the activity coefficient of AB, a trivalent ion, will have a negative deviation from  $\log^{-1}(-0.5 z^2 \sqrt{\mu})$  still greater than that of the persulfate ion, and the value of  $\log f_A f_B / f_{AB}$  will therefore be greater than calculated and used in deriving equation (1). At higher concentrations the logarithmic value will again be equal to and finally less than  $z_A z_B \sqrt{\mu}$ .

For this reason we prefer to take the limiting equation found with added uni-univalent salts, namely

$$\log k = -1.075 + 2\sqrt{\mu}$$

as extrapolating to the best value of  $k_0$ , the velocity constant at zero ionic strength. This gives the value

$$k_0 = 0.0841$$

<sup>12</sup> Brønsted, La Mer and others, THIS JOURNAL, 43, 2265 (1921); 46, 555 (1924); 49, 363, 410 (1927).

<sup>13</sup> Gronwall, La Mer and Sandved, *Physik. Z.*, 29, 358 (1928).

In view of the uncertainty regarding the quantitative application of the Gronwall-La Mer-Sandved equation, it is useless to attempt to apply a more or less empirically extended activity coefficient equation in explanation of the curves in Figs. 4 and 6.

### Summary

The velocity of the persulfate-iodide ion reaction has been measured, in aqueous solution at 25°, between values of  $\mu = 0.000625$  and  $\mu = 0.025$ , with an accuracy of about  $\pm 1.5\%$ .

The velocity was measured by adding small known amounts of thiosulfate to the reacting solution and noting the time of first appearance of iodine with the aid of a photo-cell circuit far more sensitive to traces of iodine than the visual starch test. The velocity constants, in solutions containing as few ions of valence higher than unity as possible, follow accurately the linear equation

$$\log k = -1.075 + 2\sqrt{\mu}$$

to at least as high a concentration as  $\mu = 0.025$ .

The small difference in the extrapolation of the plot of  $\log k$  against  $\sqrt{\mu}$  for univalent and bivalent ions may be qualitatively explained by the difference between the original Debye-Hückel limiting equation for the activity coefficient of an ion and the Gronwall-La Mer-Sandved extension for ions of higher valence than unity.

NEW YORK, N. Y.

---

[COMMUNICATION FROM THE CHEMICAL LABORATORY OF THE UNIVERSITY OF ROCHESTER]

## THE SOLUBILITY OF GOLD IN MERCURY. III

BY ARTHUR A. SUNIER AND LAW G. WEINER

RECEIVED FEBRUARY 12, 1931

PUBLISHED MAY 6, 1931

In earlier papers<sup>1</sup> the results of a study of the solubility of gold in mercury in the temperature interval 0 to 200° were presented. The present paper will deal with a similar study in the range 200 to 300°. The need of such a study will be apparent to all who critically examine the published data<sup>2</sup> in this range of temperature. Although the precision of measurement is not as great as that obtained in earlier papers, it is felt that the method and results are of sufficient interest to warrant publication at this time.

### Materials

The mercury was carefully purified and tested as described in earlier papers. In one run (B) mercury was used which was obtained by evapora-

<sup>1</sup> Sunier and Gramkee, *THIS JOURNAL*, **51**, 1703 (1929); Sunier and White, *ibid.*, **52**, 1842 (1930).

<sup>2</sup> Parravano, *Gazz. chim. ital.*, **48**, II, 123 (1918); Braley and Schneider, *THIS JOURNAL*, **43**, 740 (1921); Britton and McBain, *ibid.*, **48**, 593 (1926); Plaskin, *J. Russ. Phys.-Chem. Soc.*, **61**, 521 (1929).